

Features

- Material: SECC
- Corner mount bracket
- Aesthetic design

Technical Specifications

Model	JBF-AS-FPA-15
General	
Material	SECC
Dimension(WxHxD)	243mmx170mmx138mm (9.57"x6.69"x5.43")
Pipe Thread	N/A
Operating Temperature	-40°C ~ +60°C (-40°F ~ +140°F)
Humidity	0~90% RH
Load Bearing	10.0kg(22.05lb)
Weight	1.7kg(3.75lb)
Applicable Model	JBF-AS-2MP-PTZ, JBF-AS-2MP-PTZ-2

Dimensions (mm/inch)

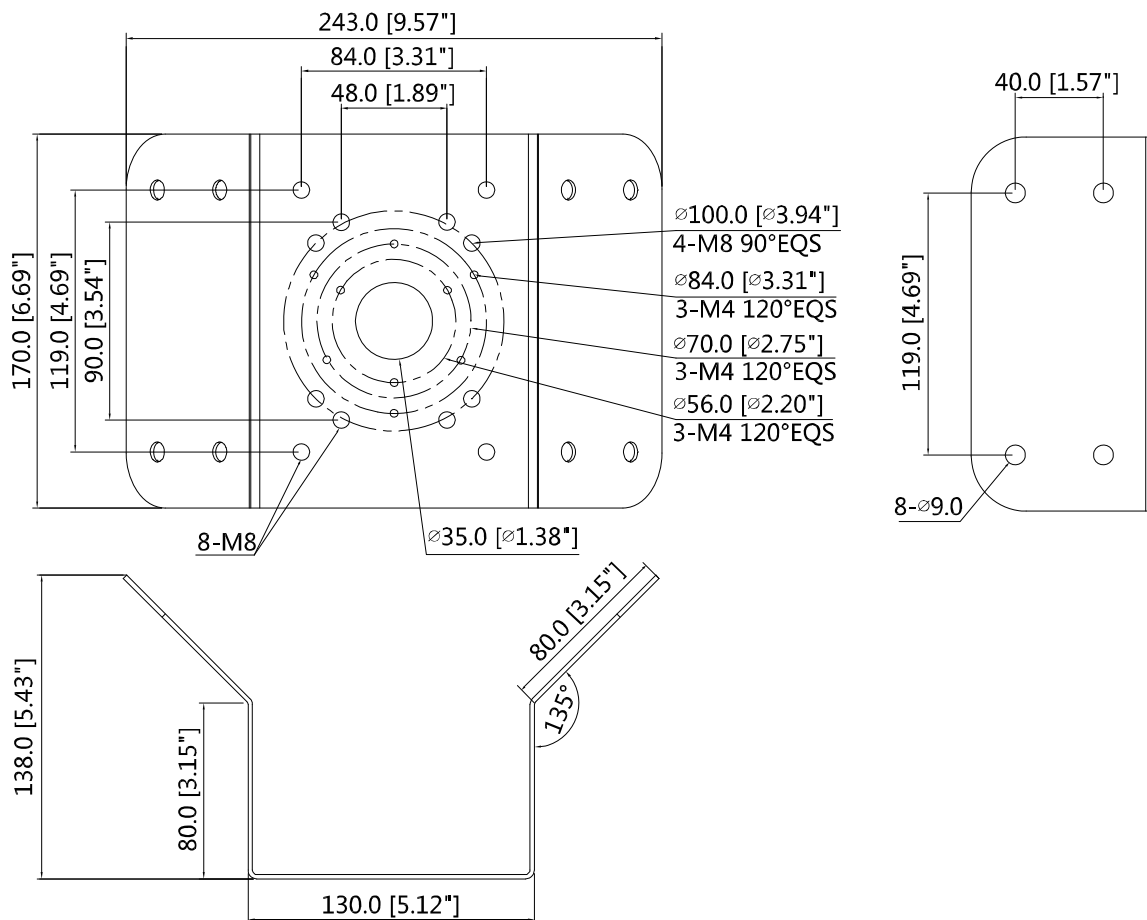

Application

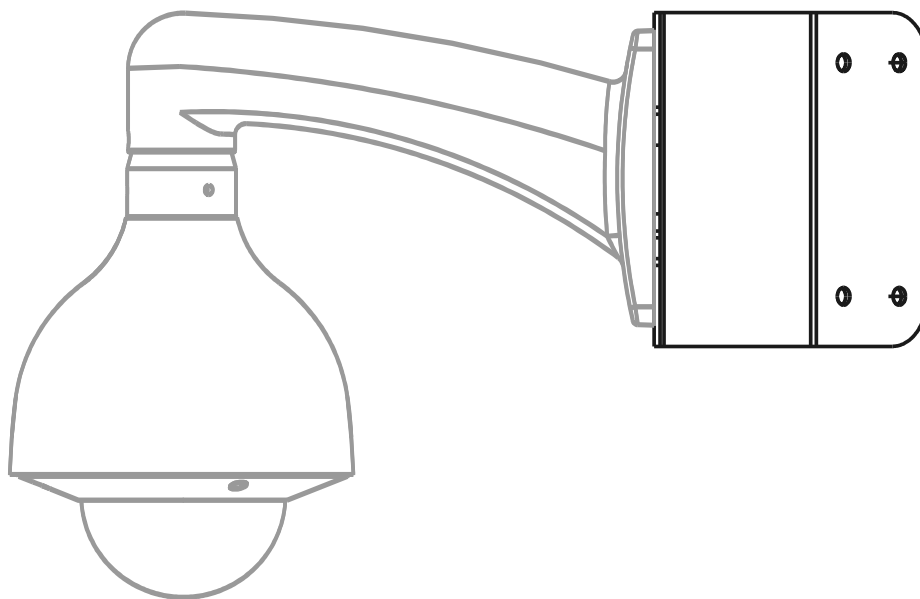

Package Information

- Corner mount bracket *1
- M8x25 screw *4
- Metal anchor *4
- Wrench *1