



Features

- Aesthetic design
- Material: aluminum
- Mount adapter

JBF-AS-FPASG

Technical Specifications

Model	JBF-AS-FPASG
General	
Material	Aluminum
Dimension	Φ60mmx49mm (Φ2.36"x1.93")
Pipe Thread	G1 1/2"
Load Bearing	7.0kg(15.43lb)
Weight	0.25kg(0.55lb)
Color	White
Operating Temperature	-40°C ~ +60°C (-40°F ~ +140°F)
Humidity	<90% RH
Applicable Model	JBF-AS-2MP-PTZ, JBF-AS-2MP-PTZ-2, JBF-AS-4X5MP-DOME, JBF-AS-4X2MP-DOME

Dimensions (mm/inch)

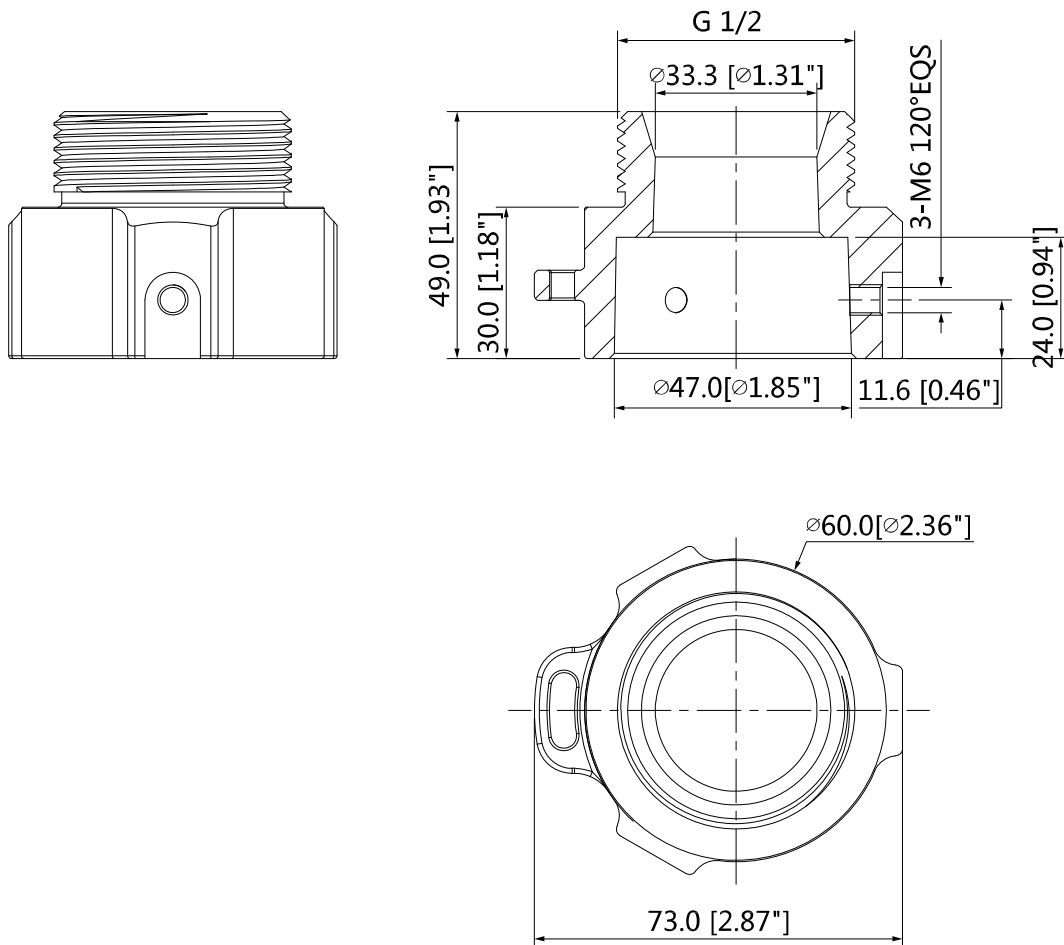

Application

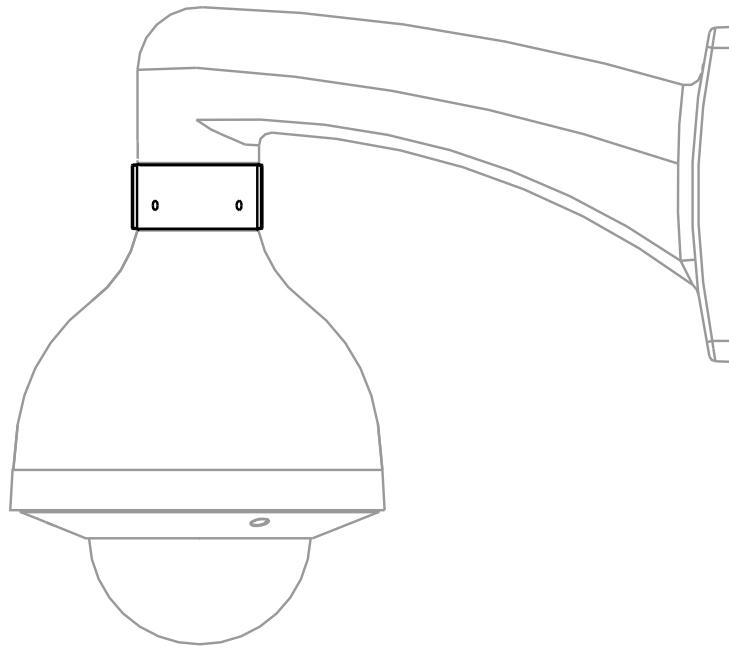

Package Information

- Mount adapter *1