



### Features

- Neat & Integrated design.
- Wall mount bracket, fast loading structure.
- Material: Aluminum.
- Come with a space at the bottom of the bracket, there are two out-holes (G3/4) designed at the bottom, which is convenient for cable hiding and wiring.
- Safety rope hook attached, secure and reliable.

# JBF-AS-FPB21W

## Technical Specifications

<b>Model</b>	JBF-AS-FPB21W
<b>General</b>	
Material	Aluminum
Dimension (W x H x D)	229.7mmx168.7mmx113.2mm(9.04"x6.64"x4.46")
Weight	0.93kg(2.05lb)
Load Bearing	3kg(6.61lb)
Color	White
Operating Temperature	-40°C ~60°C(-40°F ~140°F)
Humidity	<90% RH
Applicable Camera	JBF-AS-5MP-DOME

## Dimensions (mm/inch)

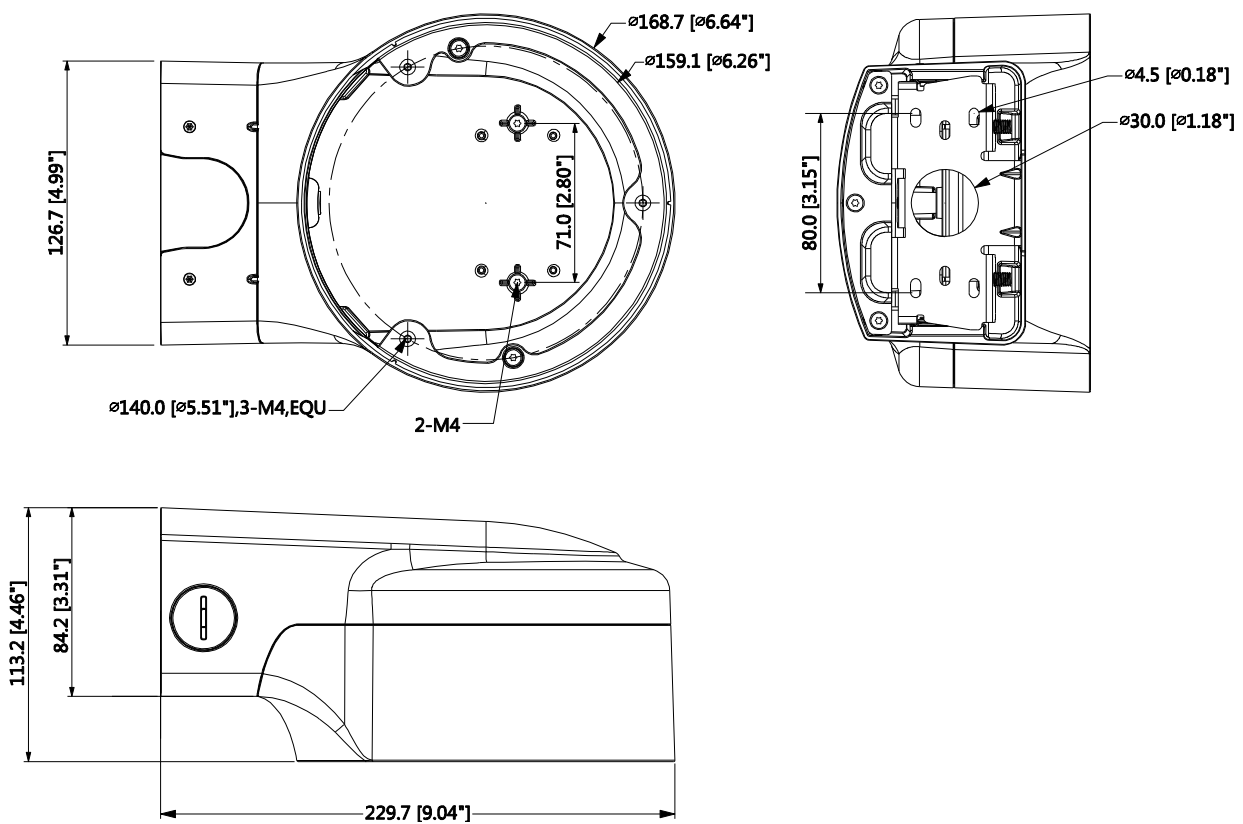

## Application

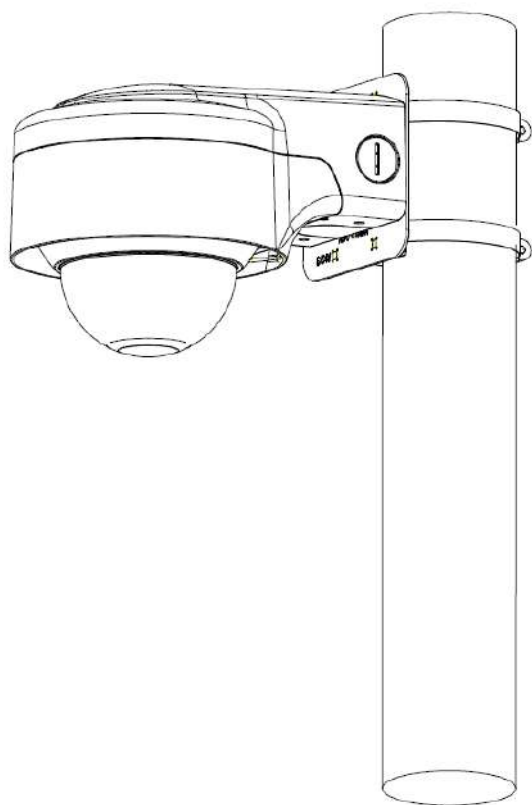

## Package Information

- Wall-proof wall mount Bracket \*1
- Application manual \*1
- ST4x25 screw&anchor \*4
- M4x18 \*3
- Wrench \*1
- Safety rope \*1