



## Features

- Neat & Integrated design.
- Wall mount bracket.
- Material: Aluminum.
- Safety rope hook attached, secure and reliable.

## Technical Specifications

<b>Model</b>	JBF-AS-FPB5W
<b>General</b>	
Material	Aluminum
Dimension(WXHXD)	200mmx160mmx115mm(7.87"x6.3"x4.53")
Weight	0.87kg(1.92lb)
Load Bearing	5.0kg(11.02lb)
Color	White
Operating Temperature	-40°C ~60°C(-40°F ~140°F)
Humidity	<90% RH
Applicable Model	JBF-AS-2MP-PTZ, JBF-AS-2MP-PTZ-2

## Dimensions (mm/inch)

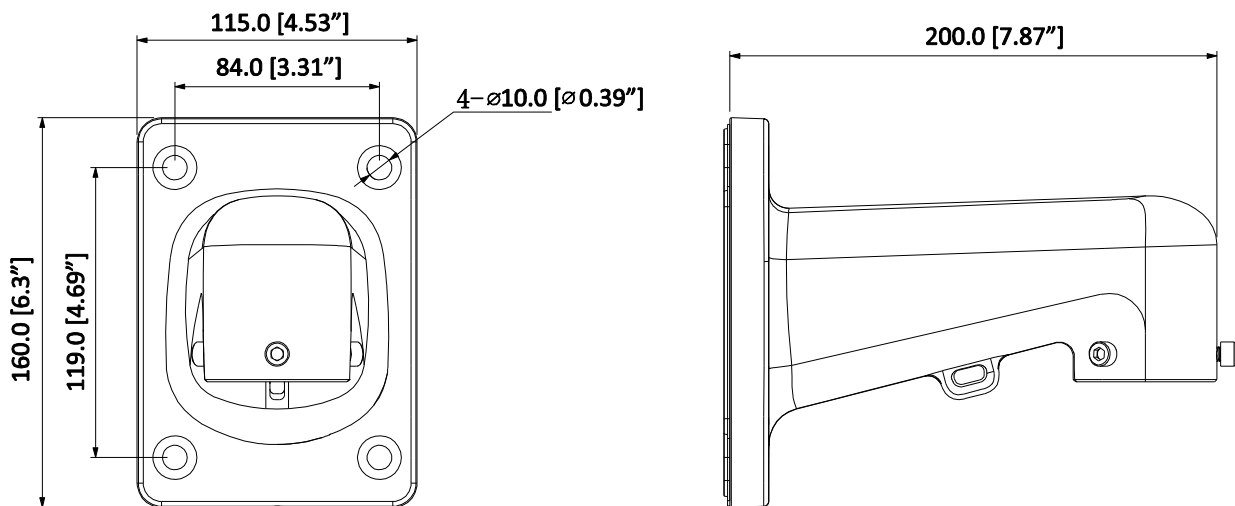

## Application

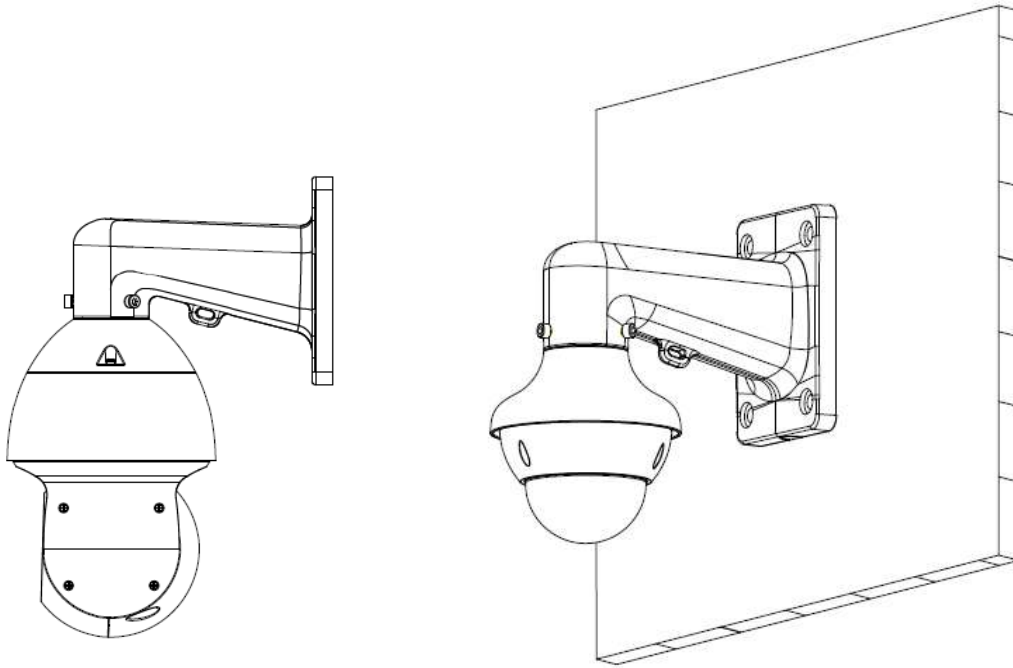

## Package Information

- Wall mount Bracket \*1
- M6 screw \*3
- Wrench \*1